

# Technical data sheet



## Product features

### Toaster 3x holders

<b>Model</b>	<b>SAP Code</b>	00004294
--------------	-----------------	----------



- Standard equipment for device: 3x tongs, grid
- Timer: Yes
- Material: Stainless steel
- Indicators: operation and warm-up
- Removable rear wall of the device: Yes
- Container for liquid fat: Yes

<b>SAP Code</b>	00004294	<b>Net Weight [kg]</b>	8.00
<b>Net Width [mm]</b>	453	<b>Power electric [kW]</b>	2.000
<b>Net Depth [mm]</b>	274	<b>Loading</b>	230 V / 1N - 50 Hz
<b>Net Height [mm]</b>	288	<b>Standard equipment for device</b>	3x tongs, grid

# Technical data sheet



Technical drawing

## Toaster 3x holders

Model

SAP Code

00004294

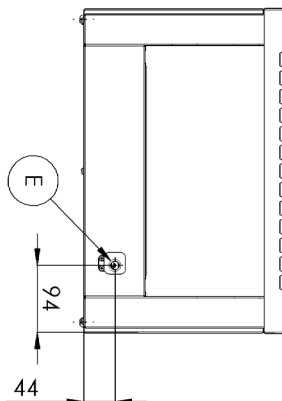
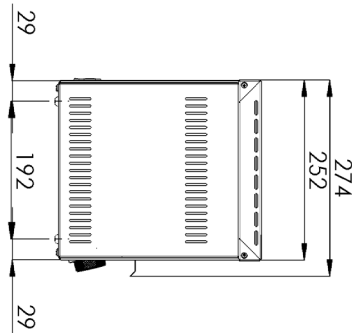
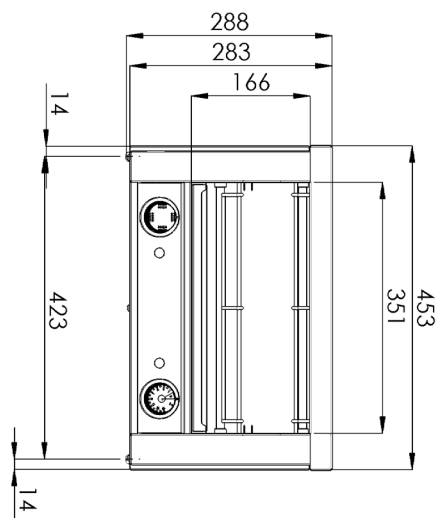

### Toaster 3x holders

Model

SAP Code

00004294

1

#### All-stainless design

only stainless steel intended for food contact is used

- absolutely rust-proof and non-magnetic design
- resists even weak acids easier compliance with hygiene standards (HACCP); easy maintenance and cleaning

2

#### Run and warm-up light

optical possibility to check the status of the device

- the operator immediately knows what state the appliance is in on/off, heating/not heating

3

#### Separate control for individual sections

the possibility of a heating system separately

- greater variability of use

4

#### Catch container for breadcrumbs

breadcrumbs fall outside the furnace

- no crumbs falling off

5

#### Removable back wall

possibility to open the back wall of the device

- possible filling of the equipment by the operator

6

#### Silicon heaters

immediate onset of heat  
intense radiant heat

- the device can be switched off even during the operating day
- toasted food vigorously and without overheating inside
- faster food preparation

7

#### The tongs and grid are part of the standard equipment

I can put the food on the grate or put it in tongs

- universally applicable equipment
- I can prepare different types of food using standard equipment

# Technical data sheet



## Technical parameters

### Toaster 3x holders

Model

SAP Code

00004294

**1. SAP Code:**

00004294

**2. Net Width [mm]:**

453

**3. Net Depth [mm]:**

274

**4. Net Height [mm]:**

288

**5. Net Weight [kg]:**

8.00

**6. Gross Width [mm]:**

355

**7. Gross depth [mm]:**

500

**8. Gross Height [mm]:**

320

**9. Gross Weight [kg]:**

9.00

**10. Device type:**

Electric unit

**11. Construction type of device:**

Table top

**12. Material:**

Stainless steel

**13. Power electric [kW]:**

2.000

**14. Loading:**

230 V / 1N - 50 Hz

**15. Standard equipment for device:**

3x tongs, grid

**16. Protection of controls:**

IPX4

**17. Timer:**

Yes

**18. Removable rear wall of the device:**

Yes

**19. Container for liquid fat:**

Yes

**20. Indicators:**

operation and warm-up

**21. Cross-section of conductors CU [mm<sup>2</sup>]:**

0,5

- Výkon (kW): 2,4-3,3 (230 V)